

PG-2 PLUS Insulated Pipe Guide

Medium Bore Pipe / Extended Travel

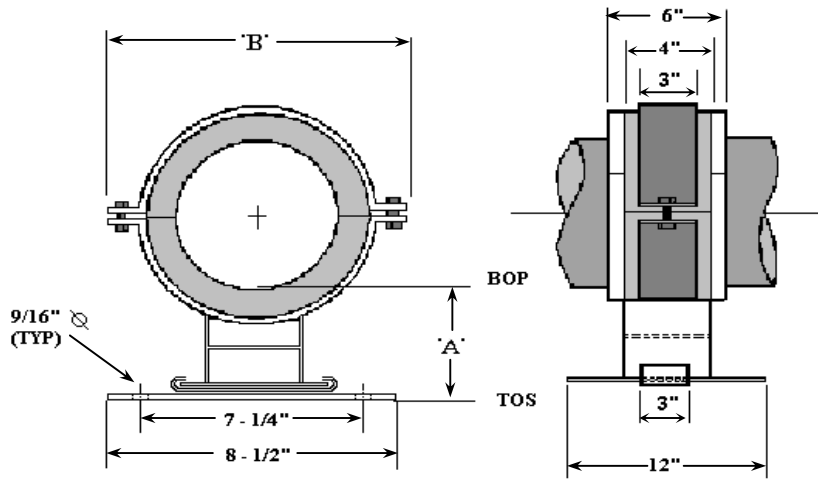

APPLICATION TABLE

Pipe Size (IPS)	Travel Allowed	Load (Lbs.)		Insulation Thickness													
		Vert.	Horz.	1"		1-1/2"		2"		2-1/2"		3"		3-1/2"		4"	
				'A'	'B'	'A'	'B'	'A'	'B'	'A'	'B'	'A'	'B'	'A'	'B'	'A'	'B'
1-1/2	+/- 4-1/2"	535	535	See PG-1				5.5	10	6.1	11	6.6	12	7.1	13	7.7	15
2	+/- 4-1/2"	670	670					5.3	10	5.9	11	6.4	12	6.9	13	7.5	15
2-1/2	+/- 4-1/2"	810	810					5	10	5.6	11	6.1	12	6.6	13	7.2	15
3	+/- 4-1/2"	990	990	4.8	10	5.3	11	5.8	12	6.3	13	7	15	7.5	16		
4	+/- 4-1/2"	1270	1270	4.3	10	4.8	11	5.3	12	5.8	13	6.4	15	7	16		
5	+/- 4-1/2"	1570	1570	4.3	11	4.8	12	5.3	13	5.9	15	6.4	16				
6	+/- 4-1/2"	1870	1870	4.3	12	4.8	13	5.4	15	5.9	16						
8	+/- 4-1/2"	2430	2430	4.4	15	4.9	16										

See PG-3 For Larger Pipe Sizes

MATERIAL SPECIFICATIONS

INSULATION INSERT

- 360° Xonotlite Calcium Silicate, Minimum 450 PSI Compressive Strength, Meeting ASTM C-533, C-585, C-795, E-72, and E-84, Flame Spread -0- Smoke Developed -0-.
- K-Factor of .54 @ 200° F.
- Heavy Gauge, G-90 Galvanized Steel Protection Shield.
- Vapor Barrier Jacket of Non-Reactive Polyester Meeting ASTM D-744, D-828 and E-84.

GUIDE HARDWARE

- Powder Coated Carbon Steel Meeting ASTM B-117 (1000 Hour Salt Spray), ASTM D-3363 (Pencil Hardness), ASTM D-3359 (Adhesion).
- Slide Pad of Heat Bonded P.T.F.E.
- Fasteners - Plated, Grade 2 Industrial.

Submitted For Approval Per:

Division: _____, Section: _____, Para.: _____.

Project: _____

Customer: _____

Engineer: _____

Notes:

Approved By: _____

Date: _____