

# PG-3 PLUS Insulated Pipe Guide

## Large Bore Pipe / Extended Travel

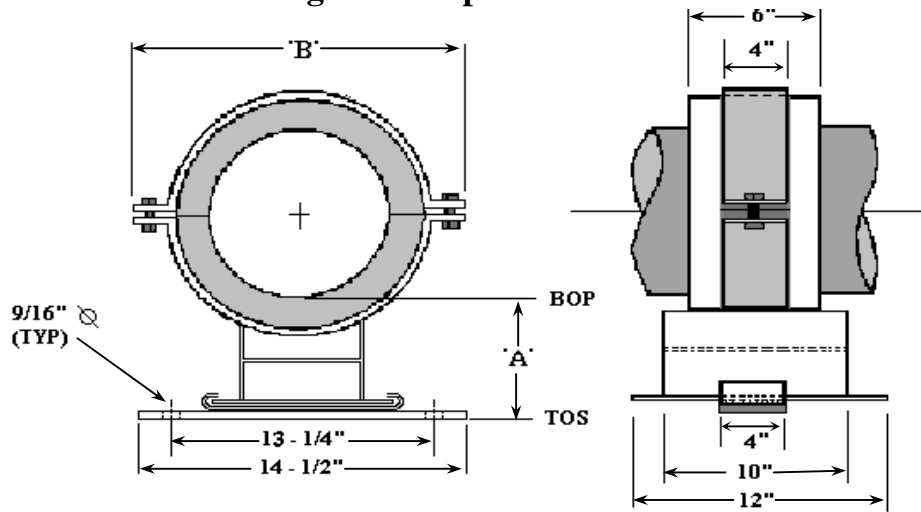

### APPLICATION TABLE

Pipe Size (IPS)	Travel Allowed	Load (Lbs.)		Insulation Thickness																							
		Vert.	Horz.	1"		1-1/2"		2"		2-1/2"		3"		3-1/2"		4"											
				'A'	'B'	'A'	'B'	'A'	'B'	'A'	'B'	'A'	'B'	'A'	'B'	'A'	'B'										
4	+/- 4-1/2"	1690	1690	See PG-2 For Medium Pipe Sizes														8.9	17								
5	+/- 4-1/2"	2100	2100	See PG-2 For Medium Pipe Sizes														8.4	17	9	18						
6	+/- 4-1/2"	2500	2500	See PG-2 For Medium Pipe Sizes														7.8	17	8.5	18	9	19				
8	+/- 4-1/2"	3250	3250	See PG-2 For Medium Pipe Sizes														6.8	17	7.5	18	8.1	19	8.6	20	9.2	21
10	+/- 4-1/2"	4050	4050	5.8	17	6.5	18	7	19	7.5	20	8.1	21	8.8	22	9.2	23										
12	+/- 4-1/2"	4800	4800	6	19	6.5	20	7.2	21	7.8	22	8.2	23	8.8	24	Call Factory For Larger Pipe Sizes											
14	+/- 4-1/2"	5300	5300	5.9	20	6.6	21	7.1	22	7.6	23	Call Factory For Larger Pipe Sizes															
16	+/- 4-1/2"	6100	6100	6.1	22	6.6	23	7.1	24	Call Factory For Larger Pipe Sizes																	

### MATERIAL SPECIFICATIONS

#### INSULATION INSERT

- 360° Xonotlite Calcium Silicate, Minimum 450 PSI Compressive Strength, Meeting ASTM C-533, C-585, C-795, E-72, and E-84, Flame Spread -0-, Smoke Developed -0-.
- K-Factor of .54 @ 200° F.
- Heavy Gauge, G-90 Galvanized Steel Protection Shield.
- Vapor Barrier Jacket of Non-Reactive Polyester Meeting ASTM D-744, D-828 and E-84.

#### GUIDE HARDWARE

- Powder Coated Carbon Steel Meeting ASTM B-117 (1000 Hour Salt Spray), ASTM D-3363 (Pencil Hardness), ASTM D-3359 (Adhesion).
- Slide Pad of Heat Bonded P.T.F.E.
- Fasteners - Plated, Grade 2 Industrial.

#### Submitted For Approval Per:

Division: \_\_\_\_\_, Section: \_\_\_\_\_, Para.: \_\_\_\_\_.

Project: \_\_\_\_\_

Customer: \_\_\_\_\_

Engineer: \_\_\_\_\_

#### Notes:

\_\_\_\_\_  
 \_\_\_\_\_  
 \_\_\_\_\_  
 \_\_\_\_\_

Approved By: \_\_\_\_\_

Date: \_\_\_\_\_