

PS-2 Insulated Pipe Slide Medium Bore Pipe

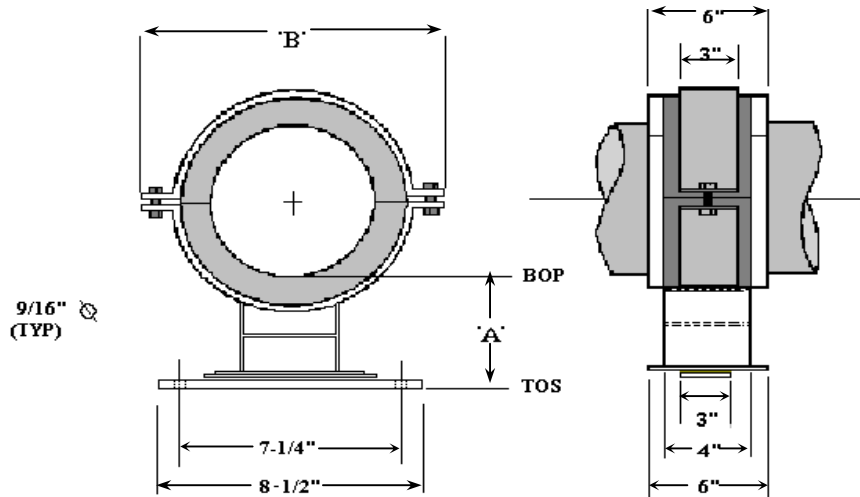

APPLICATION TABLE

Pipe Size (IPS)	Travel Allowed	Load (Lbs.) Vertical	Insulation Thickness															
			1"		1-1/2"		2"		2-1/2"		3"		3-1/2"		4"			
			'A'	'B'	'A'	'B'	'A'	'B'	'A'	'B'	'A'	'B'	'A'	'B'	'A'	'B'		
1-1/2	+/- 2"	535	See PS-1				5.5	10	6.1	11	6.6	12	7.1	13	7.7	15		
2	+/- 2"	670					5.3	10	5.9	11	6.4	12	6.9	13	7.5	15		
2-1/2	+/- 2"	810					5	10	5.6	11	6.1	12	6.6	13	7.2	15	7.8	16
3	+/- 2"	990					4.8	10	5.3	11	5.8	12	6.3	13	7	15	7.5	16
4	+/- 2"	1270	4.3	10	4.8	11	5.3	12	5.8	13	6.4	15	7	16	See PS-3 For Larger Pipe Sizes			
5	+/- 2"	1570	4.3	11	4.8	12	5.3	13	5.9	15	6.4	16						
6	+/- 2"	1870	4.3	12	4.8	13	5.4	15	5.9	16								
8	+/- 2"	2430	4.4	15	4.9	16												

MATERIAL SPECIFICATIONS

INSULATION INSERT

- 360° Xonotlite Calcium Silicate, Minimum 450 PSI Compressive Strength, Meeting ASTM C-533, C-585, C-795, E-72, and E-84, Flame Spread -0-, Smoke Developed -0-.
- K-Factor of .54 @ 200° F.
- Heavy Gauge, G-90 Galvanized Steel Protection Shield.
- Vapor Barrier Jacket of Non-Reactive Polyester Meeting ASTM D-744, D-828 and E-84.

SLIDE HARDWARE

- Powder Coated Carbon Steel Meeting ASTM B-117 (1000 Hour Salt Spray), ASTM D-3363 (Pencil Hardness), ASTM D-3359 (Adhesion).
- Slide Pad of Heat Bonded P.T.F.E.
- Fasteners - Plated, Grade 2 Industrial.

Submitted For Approval Per:

Division: _____, Section: _____, Para.: _____.

Project: _____

Customer: _____

Engineer: _____

Notes:

Approved By: _____

Date: _____