

PS-3 PLUS Insulated Pipe Slide

Large Bore Pipe / Extended Travel

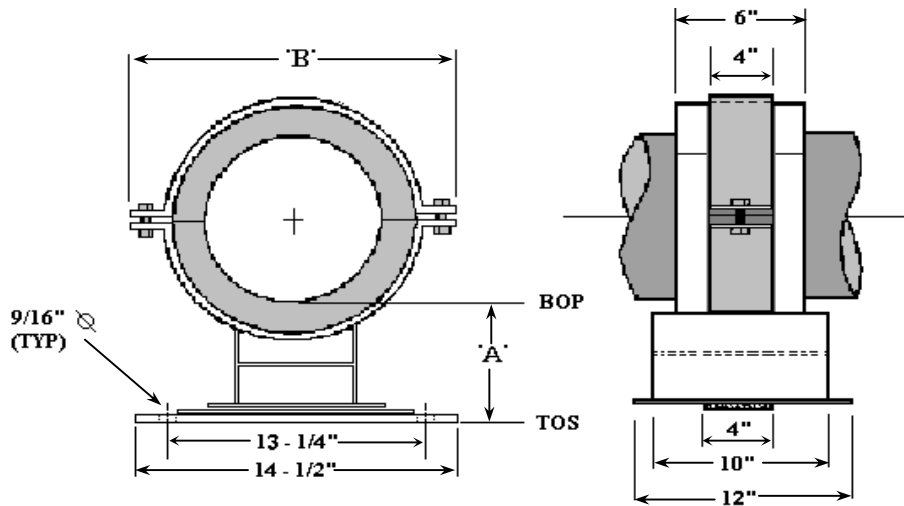

APPLICATION TABLE

Pipe Size (IPS)	Travel Allowed	Load (Lbs.) Vertical	Insulation Thickness																					
			1"		1-1/2"		2"		2-1/2"		3"		3-1/2"		4"									
			'A'	'B'	'A'	'B'	'A'	'B'	'A'	'B'	'A'	'B'	'A'	'B'	'A'	'B'								
4	+/- 4-1/2"	1690	See PS-2 For Medium Pipe Sizes												8.9	17								
5	+/- 4-1/2"	2100	See PS-2 For Medium Pipe Sizes												8.4	17	9	18						
6	+/- 4-1/2"	2500	See PS-2 For Medium Pipe Sizes												7.8	17	8.5	18	9	19				
8	+/- 4-1/2"	3250	See PS-2 For Medium Pipe Sizes												6.8	17	7.5	18	8.1	19	8.6	20	9.2	21
10	+/- 4-1/2"	4050	5.8	17	6.5	18	7	19	7.5	20	8.1	21	8.8	22	9.2	23								
12	+/- 4-1/2"	4800	6	19	6.5	20	7.2	21	7.8	22	8.2	23	8.8	24	Call Factory For Larger Pipe Sizes									
14	+/- 4-1/2"	5300	5.9	20	6.6	21	7.1	22	7.6	23	Call Factory For Larger Pipe Sizes													
16	+/- 4-1/2"	6100	6.1	22	6.6	23	7.1	24	Call Factory For Larger Pipe Sizes															

MATERIAL SPECIFICATIONS

INSULATION INSERT

- 360° Xonolite Calcium Silicate, Minimum 450 PSI Compressive Strength, Meeting ASTM C-533, C-585, C-795, E-72, and E-84, Flame Spread -0-, Smoke Developed -0-.
- K-Factor of .54 @ 200° F.
- Heavy Gauge, G-90 Galvanized Steel Protection Shield.
- Vapor Barrier Jacket of Non-Reactive Polyester Meeting ASTM D-744, D-828 and E-84.

GUIDE HARDWARE

- Powder Coated Carbon Steel Meeting ASTM B-117 (1000 Hour Salt Spray), ASTM D-3363 (Pencil Hardness), ASTM D-3359 (Adhesion).
- Slide Pad of Heat Bonded P.T.F.E.
- Fasteners - Plated, Grade 2 Industrial.

Submitted For Approval Per:

Division: _____, Section: _____, Para.: _____.

Project: _____

Customer: _____

Engineer: _____

Notes:

Approved By: _____

Date: _____