

VALUE ENGINEERED PRODUCTS, INC.

Denver, Colorado

PG-1 Insulated Pipe Guide

Small Bore Pipe

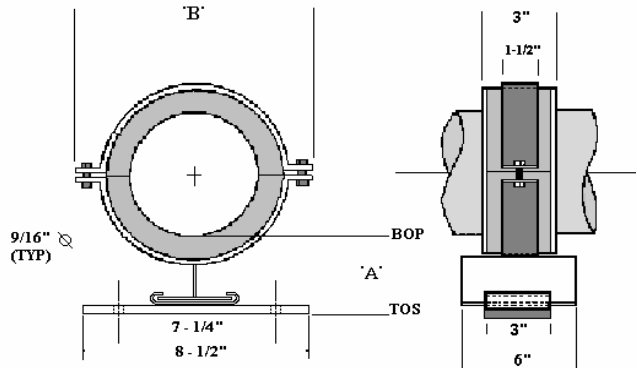

APPLICATION TABLE

Pipe Size (IPS)	Travel Allowed	Load (Lbs.)		Insulation Thickness															
				1"		1-1/2"		2"		2-1/2"		3"		3-1/2"		4"			
				'A'	'B'	'A'	'B'	'A'	'B'	'A'	'B'	'A'	'B'	'A'	'B'	'A'	'B'		
1/2	+/- 2"	115	115	4.4	6	4.9	7	5.4	9	See PG-2 and PG-3 For Larger Pipe Diameters									
3/4	+/- 2"	145	145	4.3	6	4.9	7	5.3	9										
1	+/- 2"	185	185	4.4	6.5	4.6	7	5.4	9.5										
1-1/4	+/- 2"	235	235	4.3	6.5	5	9	5.3	9.5										
1-1/2	+/- 2"	265	265	4.4	7	4.9	9												
2	+/- 2"	335	335	4.4	8	4.9	9.5												
2-1/2	+/- 2"	405	405	4.4	9														
3	+/- 2"	495	495	4.4	9.5														

MATERIAL SPECIFICATIONS

INSULATION INSERT

- 360° Xonotlite Calcium Silicate, Minimum 450 PSI Compressive Strength Meeting ASTM C-533, C-585, C-795, E-72, and E-84, Flame Spread -0-, Smoke Developed -0-.
- K-Factor of .54 @ 200° F.
- Heavy Gauge, G-90 Galvanized Steel Protection Shield.
- Vapor Barrier Jacket of Non-Reactive Polyester Meeting ASTM D-744, D-828 and E-84.

GUIDE HARDWARE

- Powder Coated Carbon Steel Meeting ASTM B-117 (1000 Hour Salt Spray), ASTM D-3363 (Pencil Hardness), ASTM D-3359 (Adhesion).
- Slide Pad of Heat Bonded P.T.F.E.
- Fasteners - Plated, Grade 2 Industrial.

Submitted For Approval Per:

Division: _____, Section: _____, Para: _____.

Project: _____

Customer: _____

Engineer: _____

Notes:

Approved by: _____

Date: _____